

## **Instructions**

**Tektronix**

**P6103B  
60 MHz 10X Passive Probe  
070-7847-06**

**CE**

Copyright © Tektronix, Inc. All rights reserved.

Tektronix products are covered by U.S. and foreign patents, issued and pending. Information in this publication supercedes that in all previously published material. Specifications and price change privileges reserved.

Printed in the U.S.A.

Tektronix, Inc., P.O. Box 1000, Wilsonville, OR 97070-1000

TEKTRONIX and TEK are registered trademarks of Tektronix, Inc.

## General Safety Summary

Review the following safety precautions to avoid injury and prevent damage to this product or any products connected to it. To avoid potential hazards, use this product only as specified.

### To Avoid Fire or Personal Injury

**Observe Maximum Working Voltage.** Do not use the P6103B probe above 300 V<sub>RMS</sub>, CAT II. Refer to the derating chart, Figure 2, on page 10.

**Do Not Elevate the Common Terminal.** The common terminal is at ground potential. Do not connect the common terminal to elevated voltages.

**Do Not Operate With Suspected Failures.** If you suspect there is damage to this product, have it inspected by qualified service personnel.

**Do Not Operate in Wet/Damp Conditions.**

**Do Not Operate in an Explosive Atmosphere.**

**Keep Product Surfaces Clean and Dry.**

### Safety Terms and Symbols

**Terms in This Manual.** These terms may appear in this manual:



---

**WARNING.** Warning statements identify conditions or practices that could result in injury or loss of life.

---



---

**CAUTION.** Caution statements identify conditions or practices that could result in damage to this product or other property.

---

---

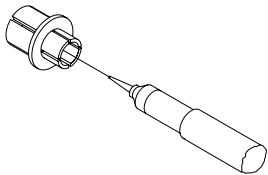
## Features and Accessories

The P6103B probe is compatible with most general purpose oscilloscopes that have a 1 M $\Omega$  input impedance and bandwidth up to 60 MHz.

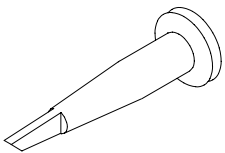
---

**NOTE.** Remove and discard the protective cover on the tip of the probe before attempting to connect a probe tip accessory.

---

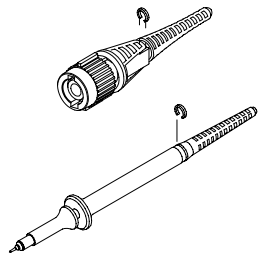


**BNC-to-probe tip adapter.** To install the adapter, push the wide end firmly into a BNC connector. Then insert the probe tip firmly into the adapter.

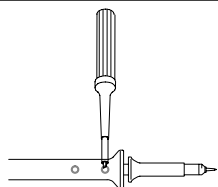


**Retractable hook tip.** Use the retractable hook tip to make hands-free measurements.

**NOTE.** For a solid connection, firmly push and twist the hook tip onto the probe tip before using.



**Marker rings.** Attach the matching colored rings onto the probe cable and tip as shown.



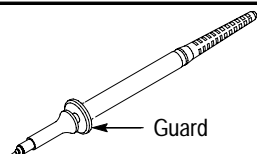
**Adjustment tool.** Use the adjustment tool for probe compensation adjustments.

---

---

Features and Accessories

---

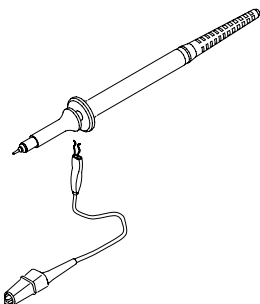


**Guard.** The guard provides a finger barrier for protection from electric shock.



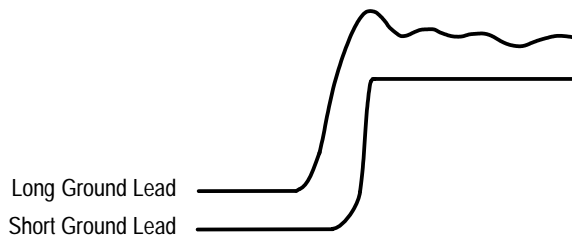
**WARNING.** To avoid electric shock when using the probe, keep fingers behind the guard on the probe body.

---



**Ground Lead.** Use the alligator clip to attach the probe to a ground reference.

---



To see the best signal, use the shortest possible ground lead and signal path.

## Maintenance

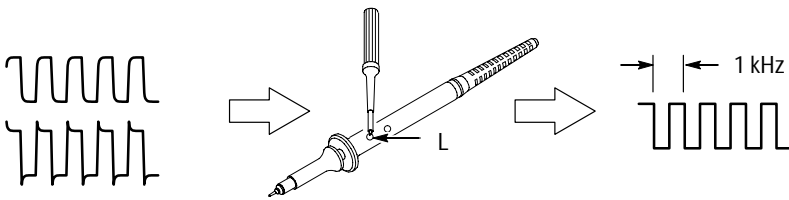
This section describes how to maintain the probe.

### Low-Frequency Probe Compensation

Before taking any measurements using a probe, first check the compensation of the probe and adjust it to match the channel inputs.

Most oscilloscopes have a square wave reference signal available at a terminal on the front panel used to compensate the probe. Connect the probe to the signal source to display a 1 kHz test signal on your oscilloscope.

Compensate the probe by adjusting **L** on the probe so that the corners of the square wave are square.



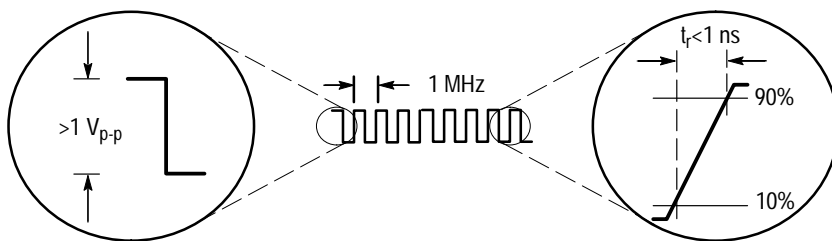
Adjust trimmer **L** until you see a flat-top square wave on the display.

## High-Frequency Probe Compensation

The probe high-frequency compensation should seldom require adjustment; however, your probe may require high-frequency adjustment if any of the following are true:

- the probe has high-frequency aberrations
- the probe does not perform at the rated bandwidth
- you have installed the probe on an oscilloscope having an input capacitance near the limits of the probe compensation range (See Table 1.)

To perform the high-frequency compensation adjustment you will need a signal source that has all of the following characteristics:

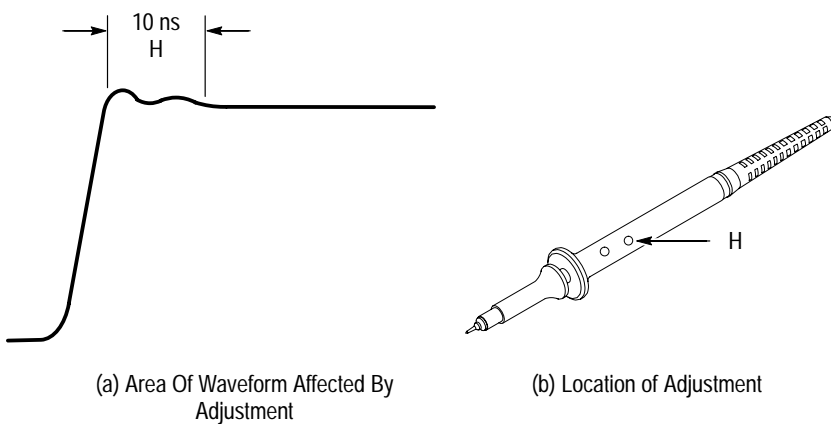


- square-wave output at 1 MHz
- fast rise output with rise time less than 1 ns
- output properly terminated

## Maintenance

---

Connect the probe to the signal source to display a 1 MHz test signal on your oscilloscope. The display should be similar to that shown in Figure 1(a).



**Figure 1: HF Compensation**

Adjust trimmer **H** until the waveform is flat on top and has a square leading edge.

## Cleaning

To prevent damage to probe materials, avoid using chemicals that contain benzene, toluene, xylene, acetone, or similar solvents.

Do not immerse the probe or use abrasive cleaners.

Dirt may be removed with a soft cloth dampened with a mild detergent and water solution, or isopropyl alcohol.



## Replacing Probe Parts

Other than accessories, only the probe tip is replaceable.

Replacement probe tips are available as optional accessories. Refer to the replaceable parts list at the end of this manual for more information.

To remove a tip assembly, firmly grasp the pointed tip with pliers and withdraw the assembly from the barrel.

No tools are required to install a replacement tip. Insert a new probe tip into the probe barrel as far as possible using finger pressure. If necessary, seat the plastic portion of the tip against the probe barrel by pressing the tip gently but firmly against a hard surface, such as a wood block or table top.

## Specifications

These characteristics apply to a P6103B probe installed on a Tektronix 2225 oscilloscope. When used with another instrument, the instrument must have an input impedance of  $1\text{ M}\Omega$  and a bandwidth not less than 60 MHz or more than 70 MHz.

The instrument must have a warm-up period of at least 20 minutes and be in an environment that does not exceed the limits described in Table 2.

**Table 1: Electrical Characteristics**

Attenuation (system)	$10X \pm 1.3\%$ at DC
Input Resistance (system)	$10\text{ M}\Omega \pm 1.3\%$
Input Capacitance	11.8 pF to 14.8 pF (13.3 pF nominal)
Compensation Range	15 pF to 35 pF
System Bandwidth (-3 dB)	DC to 60 MHz
Maximum Working Input Voltage	300 V, CAT II (See Figure 2 on page 10)

## Specifications

**Table 2: Physical and Environmental Characteristics**

Net Weight (including accessories)	< 320 g (0.7 lb)
Cable Length	2 meters
Temperature Range <sup>1</sup>	
Operating	-15° C to +65° C (+5° F to +149° F)
Nonoperating	-62° C to +85° C (-80° F to +185° F)
Humidity <sup>1</sup>	95% to 97% Relative Humidity (30°C to 60°C)

<sup>1</sup> Tektronix Standard 062-2847-00, class 3. Refer to MIL-E-16400F, paragraph 4.5.9 through 4.5.9.5.1, class 4.

**Table 3: Certifications and compliances**

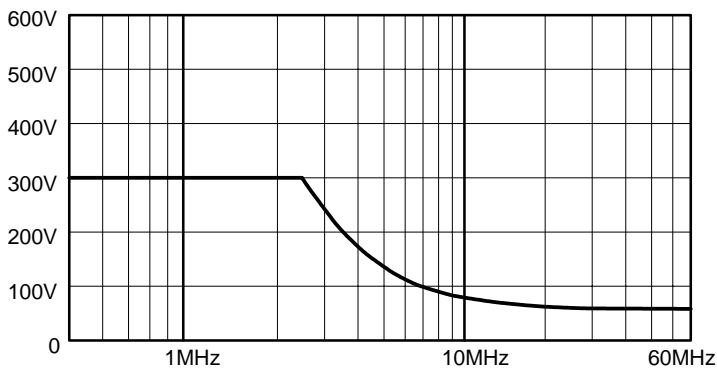
EC Declaration of Conformity – Low Voltage	<p>Compliance was demonstrated to the following specification as listed in the Official Journal of the European Communities:</p> <p>Low Voltage Directive 73/23/EEC, as amended by 93/68/EEC:  EN 61010-1/A2:1995  Safety requirements for electrical equipment for measurement, control, and laboratory use  EN 61010-2-031:1994  Particular requirements for hand-held probe assemblies for electrical measurement and test equipment</p>
Approvals	<p>UL3111-1 – Standard for electrical measuring and test equipment</p> <p>IEC 1010-2-031 – Particular requirements for hand-held probe assemblies for electrical measurement and test</p> <p>CAN/CSA-C22.2 No. 1010.1-92 and CAN/CSA-C22.2 No. 1010.2.031-94 – Safety requirements for electrical equipment for measurement, control, and laboratory use</p>

Specifications

---

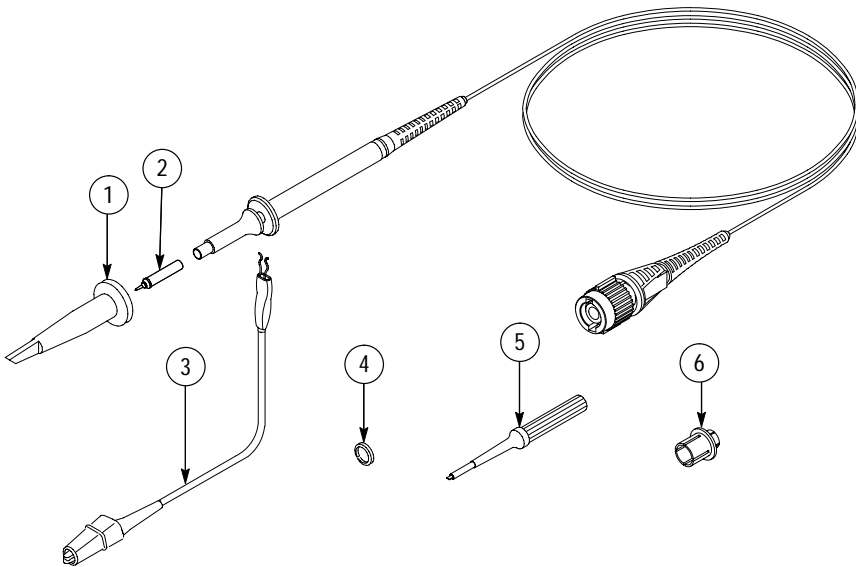
**Table 3: Certifications and compliances (Cont.)**

Installation Category Descriptions	<p>Terminals on this product may have different installation category designations. The installation categories are:</p> <p>CAT III Distribution-level mains (usually permanently connected). Equipment at this level is typically in a fixed industrial location</p> <p>CAT II Local-level mains (wall sockets). Equipment at this level includes appliances, portable tools, and similar products. Equipment is usually cord-connected</p> <p>CAT I Secondary (signal level) or battery operated circuits of electronic equipment</p>
Pollution Degree 2	Do not operate in environments where conductive pollutants may be present.

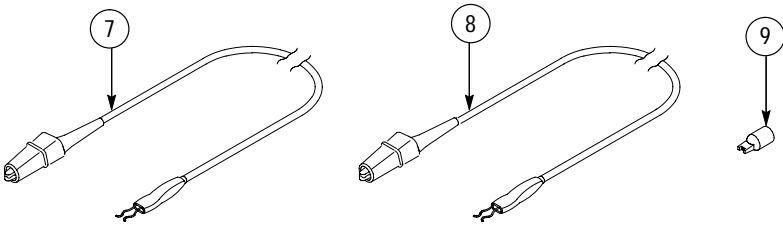


**Figure 2: Maximum Working Voltage Derating Curve (V<sub>RMS</sub>)**

# Replaceable Parts



Standard Accessories



Optional Accessories

Figure 3: P6103B replaceable parts

## Replaceable Parts List

Fig. & Index Number	Tektronix PartNumber	Serial No. Effective	Serial No. Discont'd	Qty	Name & Description	Mfr. Code	Mfr. Part Number
2-	-----			1	PROBE,PASSIVE:P6103B		
					<b>STANDARD ACCESSORIES</b>		
	020-2134-01			1	ACCESSORY KIT:MINIATURE SIZE (Includes items 1, 3, 4, 5, & 6)	80009	020-2134-01
-1	013-0107-08			1	TIP,PROBE:MINIATURE/COMPACT SIZE	TK2565	013-0107-08
-2	See Opt. Acc			1	CONTACT,ELEC:PROBE TIP W/INSULATOR ASSY		
-3	196-3120-01			1	LEAD,ELECTRICAL:PROBE GND,6.0 L	80009	196-3120-01
-4	016-0633-00			1	MARKER SET,CA:2 EA VARIOUS COLORS	80009	016-0633-00
-5	See Opt. Acc.			1	SCREWDRIVER:ADJUSTMENT TOOL		
-6	013-0277-00			1	ADAPTER,CONN:BNC TO MINIATURE PROBE TIP	24931	33A129-1
	070-7847-06			1	MANUAL,TECH:INSTR, P6103B, DP	80009	070-7847-06
					<b>OPTIONAL ACCESSORIES</b>		
-2	131-4997-01			1	CONTACT,ELEC:2 TIP-INSULATOR W/INFO CARD	80009	131-4997-01
-5	003-1433-01			1	SCREWDRIVER:ADJUSTMENT TOOL,PKG OF 5	80009	003-1433-01
-7	196-3120-21			1	LEAD,ELECTRICAL:PROBE GND,28.0 L	80009	196-3120-21
-8	196-3121-01			1	LEAD,ELECTRICAL:PROBE GND,12.0 L	80009	196-3121-01
-9	015-0201-07			1	TIP,PROBE:IC TEST,PKG OF 10	80009	015-0201-07

**Manufacturers Cross Index**

---

<b>Mfr. Code</b>	<b>Manufacturer</b>	<b>Address</b>	<b>City, State, Zip Code</b>
24931	BERG ELECTRONICS INC	BERG ELECTRONICS RF/COAXIAL DIV 2100 EARLYWOOD DR PO BOX 547	FRANKLIN, IN 46131
80009	TEKTRONIX INC	14150 SW KARL BRAUN DR PO BOX 500	BEAVERTON, OR 97077-0001
TK2565	VISION PLASTICS INC	26000 SW PARKWAY CENTER DRIVE	WILSONVILLE, OR 97070

## WARRANTY

Tektronix warrants that the products that it manufactures and sells will be free from defects in materials and workmanship for a period of one (1) year from the date of shipment. If a product proves defective during this warranty period, Tektronix, at its option, either will repair the defective product without charge for parts and labor, or will provide a replacement in exchange for the defective product.

In order to obtain service under this warranty, Customer must notify Tektronix of the defect before the expiration of the warranty period and make suitable arrangements for the performance of service. Customer shall be responsible for packaging and shipping the defective product to the service center designated by Tektronix, with shipping charges prepaid. Tektronix shall pay for the return of the product to Customer if the shipment is to a location within the country in which the Tektronix service center is located. Customer shall be responsible for paying all shipping charges, duties, taxes, and any other charges for products returned to any other locations.

This warranty shall not apply to any defect, failure or damage caused by improper use or improper or inadequate maintenance and care. Tektronix shall not be obligated to furnish service under this warranty a) to repair damage resulting from attempts by personnel other than Tektronix representatives to install, repair or service the product; b) to repair damage resulting from improper use or connection to incompatible equipment; c) to repair any damage or malfunction caused by the use of non-Tektronix supplies; or d) to service a product that has been modified or integrated with other products when the effect of such modification or integration increases the time or difficulty of servicing the product.

**THIS WARRANTY IS GIVEN BY TEKTRONIX IN LIEU OF ANY OTHER WARRANTIES, EXPRESS OR IMPLIED. TEKTRONIX AND ITS VENDORS DISCLAIM ANY IMPLIED WARRANTIES OF MERCHANTABILITY OR FITNESS FOR A PARTICULAR PURPOSE. TEKTRONIX' RESPONSIBILITY TO REPAIR OR REPLACE DEFECTIVE PRODUCTS IS THE SOLE AND EXCLUSIVE REMEDY PROVIDED TO THE CUSTOMER FOR BREACH OF THIS WARRANTY. TEKTRONIX AND ITS VENDORS WILL NOT BE LIABLE FOR ANY INDIRECT, SPECIAL, INCIDENTAL, OR CONSEQUENTIAL DAMAGES IRRESPECTIVE OF WHETHER TEKTRONIX OR THE VENDOR HAS ADVANCE NOTICE OF THE POSSIBILITY OF SUCH DAMAGES.**



